



EZ-ADVANTAGE ERECTORS

SUPPLYONE
PACKAGING ELEVATED



2EZ-A SERIES

BUILT FOR SPEED, FLEXIBILITY, AND UPTIME



WHY THE 2EZ-A SERIES?

The 2EZ-A Series is Combi's most advanced case erector line yet – designed from the ground up to solve the real-world challenges faced by today's manufacturers.

Whether you're expanding operations, battling labor shortages, or simply looking for better value, the 2EZ-A Series delivers:

- Faster lead times available exclusively through the Combi EZ-Advantage Program
- Greater application flexibility
- Simplified maintenance and diagnostics
- Reliable performance shift after shift, year after year

COMPELLING BENEFITS

- **Modular by Design, Tailored by Need:**
Pre-engineered options simplify the order process and allow customization without the wait.
- **Rapid ROI™:**
Faster delivery means your automation investment starts to impact your bottom line sooner.
- **Ease of Installation and Use:**
Designed for quick startup and intuitive operation.
- **Proven Combi Reliability:**
Backed by our reputation for rugged equipment and outstanding aftermarket support.

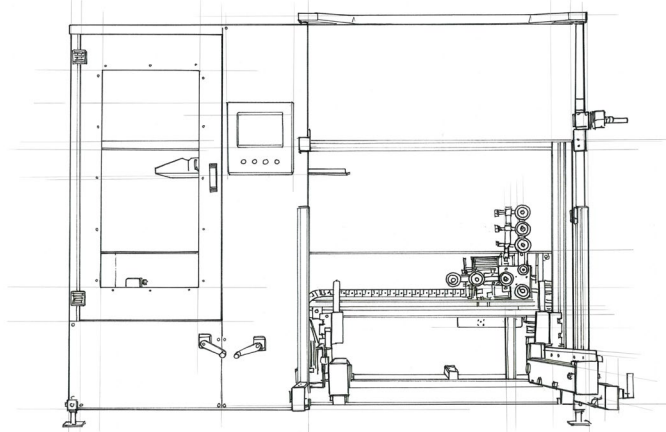

WHAT'S NEW IN THE 2EZ-A SERIES?

FIELD-UPGRADEABLE DESIGN

- Increase speed over time without the need to purchase a new machine.
- Easily expand case capacity by swapping the standard 4' magazine with a 6' kit.
- Easily swap between 2" and 3" tape heads without tools.

WIDER CASE RANGE & BETTER ERGONOMICS

- Smaller minimum case size. Width reduced from 6" to 4" and length reduced from 8" to 7" to support more applications.
- Redesigned case handling unlocks the full size range without the need for change parts.
- New opposite-hand case modification accessory does not limit standard case range.
- Relocated adjustment handles reduce operator reach to help minimize strain.

GENEROUS CASE RANGE

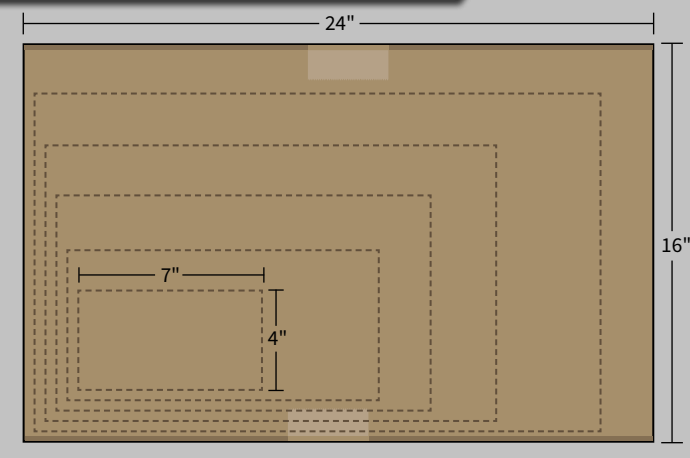

SIMPLIFIED SERVICE & MAINTENANCE

- Modular assemblies minimize downtime and lower repair costs.
- Improved access to key components like carriage bearings and motors.
- Isolated pneumatic valve bank allows safe adjustments while machine is running.
- Universal vacuum plate accepts multiple cup sizes with no tweaking.



SMARTER CONTROLS & DIAGNOSTICS

- I/O Link for fast, real-time troubleshooting.
- Plug-and-play replacements with quick disconnects and no programming required.
- Enhanced HMI with visual feedback for operators.

BUILT FOR LONG-TERM RELIABILITY

- Reinforced vacuum pick assembly increases stiffness and improves consistency.
- Redesigned carriage bearings and rails boost longevity and simplify maintenance.
- New belt drive system eliminates external gearboxes to reduce failure points.



WHAT YOU GET:

- Designed for Customization: Pre-engineered selections for faster quoting.
- Quick Ship Availability: Get the system you need, when you need it.
- Best-In-Class Support: From installation through long-term operation.





PART OF THE COMBI EZ-ADVANTAGE PROGRAM

All 2EZ-A Series machines are available through Combi's EZ-Advantage Program, which simplifies the buying process and speeds up delivery without compromising performance.

EZ-ADVANTAGE CASE ERECTORS

SPECIFICATIONS	2EZ-A 15	2EZ-A 20	2EZ-A 25	2EZ-A 30
Max. Speed	15 CPM	20 CPM	25 CPM	30 CPM
Minimum Case Range	7" x 4" x 5"	7" x 4" x 5"	7" x 4" x 5"	7" x 4" x 5"
Maximum Case Range	24" x 16" x 18"	24" x 16" x 18"	24" x 16" x 18"	20" x 13.5" x 18"
Magazine Capacity	150/230 (6')	150/230 (6')	150/230 (6')	150/230 (6')
Case Modification Available	N	Y	Y	Y
IP 56/NEMA 4X	N	N	N	N
Glue Version	N	N	N	N
Opposite Case Hand Option	N	Y	Y	Y
Standard Voltage	110 1PH	240 3PH	240 3PH	240 3PH
SCFM - 80 PSI - 3/4 Supply Line	20 SCFM	19 SCFM	14 SCFM	16 SCFM
Footprint	8' x 9'6" x 6'8"	8' x 9'6" x 6'8"	8' x 9'6" x 6'8"	8' x 9'6" x 6'8"
Approx. Shipping Weight	~2300 lbs	~2300 lbs	~2300 lbs	~2300 lbs



- **FIELD-UPGRADEABLE DESIGN**
- **WIDER CASE RANGE & BETTER ERGONOMICS**
- **SIMPLIFIED SERVICE & MAINTENANCE**
- **SMARTER CONTROLS & DIAGNOSTICS**
- **BUILT FOR LONG-TERM RELIABILITY**